

Truck-mounted concrete pump

SY62 RZ6-200

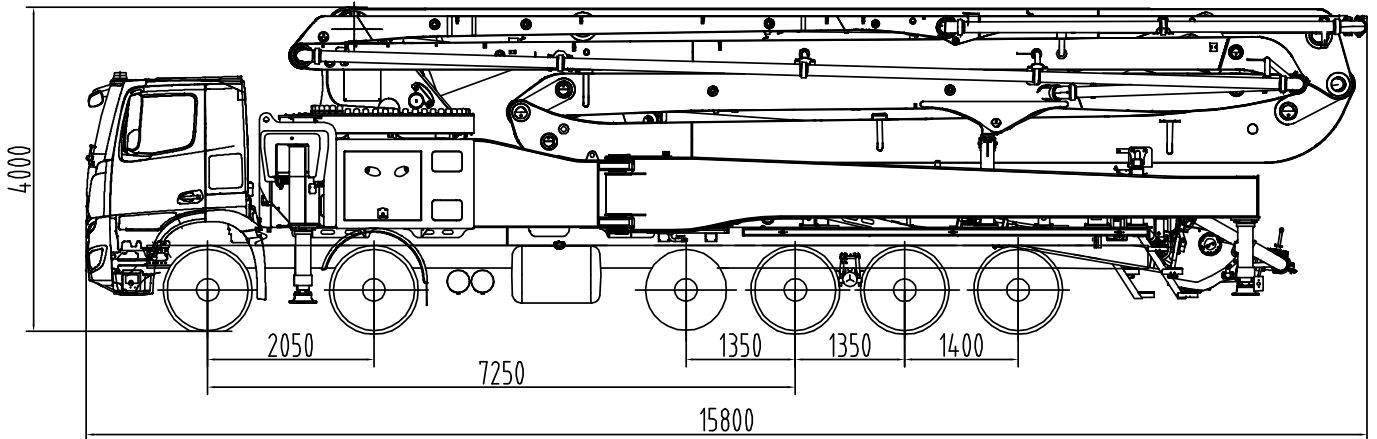

Note: Standard version. Dimensions and weights depend on truck, pump model and equipment. For illustration only.

Technical data		
Boom	Folding system	6-arm RZ
	Vertical reach	61.1 m
	Horizontal reach	56.7 m
	Reach depth	41.7 m
	Unfolding height	16.2 m
	End hose length	3 m
Support	Outrigger spread front	11.4 m
	Outrigger spread rear	13.9 m
Dimensions	Overall length	15.8 m
	Width	2.55 m
	Height	4.0 m
Core pump	Output	160 m ³ /h
	Pressure	85 bar
	Strokes/min	26
	Delivery cylinder Ø	260 mm
	Stroke length	1900 mm

Reach diagram / support

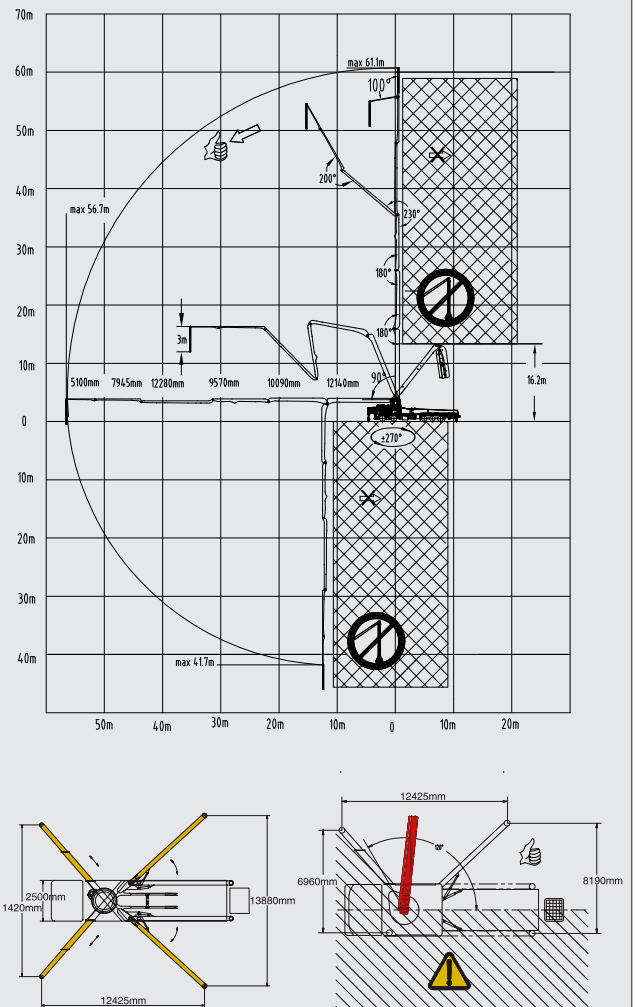

Standard Equipment SY62 RZ6-200

Chassis	Transfer Gear Box
	Towing eye
Cleaning	Water tank 600 l
	Water pump 150 l/min 20 bar
Delivery line	2-layer delivery line – DN 125, 5.5"
	End hose 3 m DN 125, 5.5"
Hopper	Concrete hopper with agitator
	Central lubrication hopper, hydraulically
	Hard metal wear parts kit
	Switchover cylinder diameter = 100mm
	Agitator safety switch off, lever switch
Lighting	Working light for illuminating hopper
	Side marker lamps
Pump	Core pump with 1900 mm stroke
	Delivery cylinder with 260 mm diameter
	Core pump with 160 m ³ /h delivery rate
	Delivery cylinder chrome-plated
	Delivery piston standard
Control System	SANY SYLD user interface display
	SANY SYMC control system
	Radio remote control propotional
	2nd radio remote control incl. 40 m cable
Support	Boom pedestal (X-type outrigger and swing out legs)
	OSS one side support (assistance device)
	Support plates (4x) in magazine (2x) open
	Swivel support plates

Safety	Chassis horn via remote control on hopper
	Handrail on rearsteps
	Horn at the boom, button on rear controlbox
	Warning device boom not in cradle
Additional features	User manual and spare part list
	Stowage Box
	Painting: pedestal and hopper in RAL 9016 Traffic white
EU KIT	Painting: arm assembly and delivery line in RAL 9016 Traffic white
	Support Stability Control (safety system)
	CE Certification & Documentation
	EU road approval KIT (markers & underrun protection)
	Platform aluminum
	Rear steps, left & right side
	Plastic hopper cover, foldable
	Vibrator on hopper grid radio remote/on site controlled

Available Options

End hose with squeezing valve "drop stop"
High Pressure Cleaner
Customer Painting in two colors (TIER 2)

See quotation for exact serial delivery scope.

Materials and specifications are subject to change without further notice in accordance with our continuous technical innovations. Photos and illustrations may include additional equipment.
All rights reserved. 2207

Putzmeister Concrete Pumps GmbH

Max-Eyth-Straße 10 · 72631 Aichtal, Germany
P.O.Box 2152 · 72629 Aichtal
Tel. +49 (7127) 599-0 · Fax +49 (7127) 599-520
pmw@putzmeister.com · www.putzmeister.com