

Putzmeister

PUMI®

24-3.67 Q

Truck-mounted concrete pump with mixer

Rotor pump system

MN 101228.008

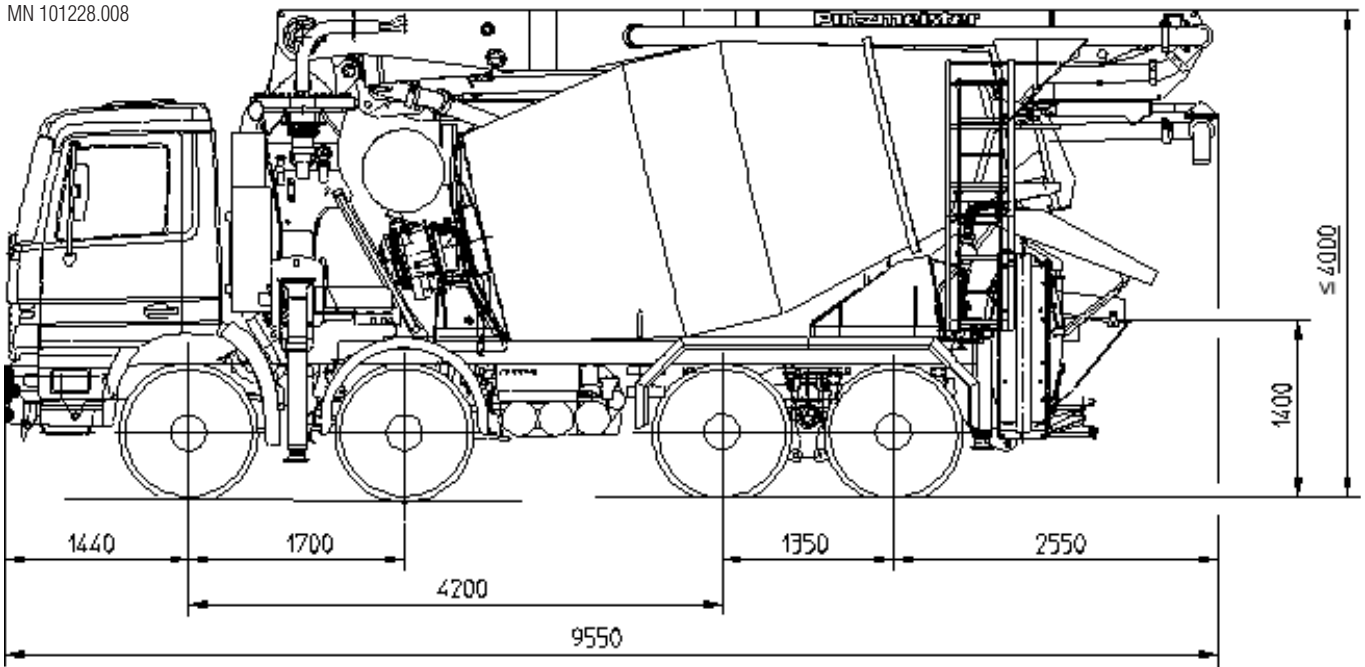

Note: Standard version. Dimensions and weights depend on boom, mixer and chassis.
Dimensions in mm, MB-Actros as example, total height depends on the chassis.

Technical data

Boom TMM 24-3		
Number of arms		3
Reach height	m	23.8
Horizontal reach	gross	m 20.0
	net	m 17.6
Reach depth max.	m	12.4
Unfolding height	m	6.9
End hose length	m	3
Folding system		Z fold (Z)
Delivery line		DN 125 – 5.5

Pump TMP 60 Q		
Output	m ³ /h	58
Delivery pressure	bar	25
Pumping hose	Ø mm	125

Maximum outputs of 58 m³/h and maximum concrete pressures of 25 bar may be achieved, depending on the equipment of the machine.

It is not possible to achieve maximum outputs and maximum concrete pressures simultaneously.

All data maximum theoretical.

Truck mixer 7 cbm		
Nominal capacity	m ³	7
Total capacity	m ³	11.5
Filling ratio	%	63
Power consumption	kW	52
Drum speed	rpm	1 - 14
Pressure tank for water	l	650

Reach information diagram, Support, Transfer tube

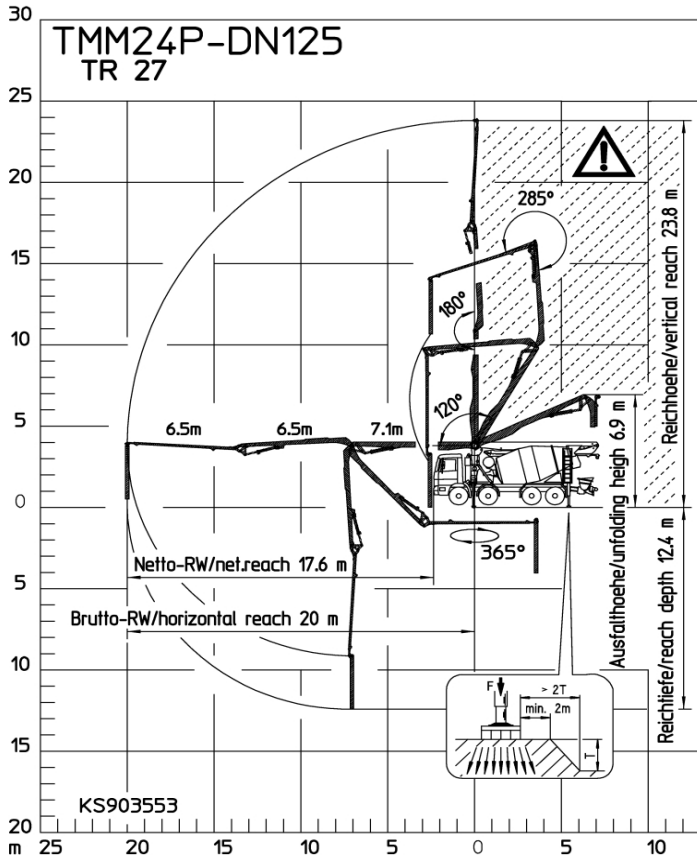

(F=160 kN)

(F=105 kN)

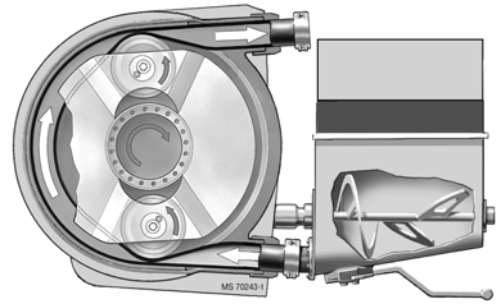
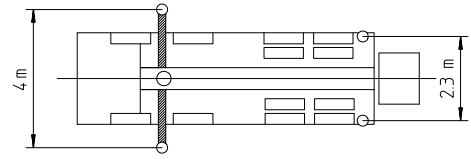

Range in which you must not work with the end hose.

Delivery scope

Support
Support legs rear T 0
Support legs T 4
Support plates 4 x in 2 magazines
Illumination
Hand working search light 1x
Marker lamps lateral and rear side, EU
Working light for hopper illumination, mounted
Extras
Operating manuals 2 x (1 x paper, 1 x CD-ROM) spare part list
Painting: mixer MB 1227 chrome yellow pump MB 1227 chrome yellow arm assembly RAL 3020 signalred
Tool set incl. standard equipment
Chassis horn operated in control box
Compressed air connection
Towing eye
Vacuum pump
Vakuumpumpe
Remote control
Radio remote control fully prop. with display

Remote control CPC with 25 m cable
Control platform with display, rear side
Electric control box with display and ergonomic diag. interface
EOC (Ergonic output control)
EPS (Ergonic pump system)
Information concrete stiffness on display
Mixer control via chassis cabin with display
Mixer-comfort-functions through display radio remote
Delivery line
Delivery line (1-layer) PM40, arm assembly
End hose 3,0 m DN 125, 5,5"
Mixing drum
Truck mixer 7 cbm
Water tank 650 l, pressure tank
Water tap under water tank
Watertank filling from both sides
EMC (Ergonic mixer control)
Chute adjustment hydraulic mechanically
Chute extension steel 1 x
Ladder, telescopic
Mixer discharge automatically
Second drip ring on mixer drum
Wear plate on discharge hopper
Wear plate on inlet hopper

Cleaning
High pressure water pump 100 bar with running dry connection
Cleaning hose with nozzle
Bracket for hammer and cleaning brush
Cardan shaft maintenance free
Safety
Agitator safety switch off
Cleaning hose with nozzle
Lateral underrun protection
Mudguard cpl. aluminium (bulb plate), rear axle
Underrun protection, rear side
Stowage Compartment
Hose bracket for 6 x DN 65 5m for 4-axle
Tool box plastic
Hopper
Concrete hopper with agitator
Rubber collar on concrete hopper
Central lubrication hopper, electrically
Level indicator

See quotation for exact serial delivery scope.
Comprehensive range of options available on request.