

Spare parts list

Handheld pneumatic breakers

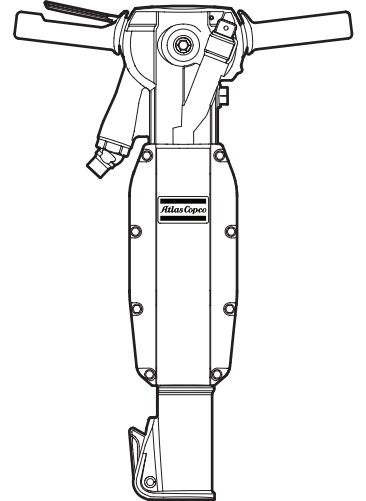

Contents

General information	5
Spare parts list	6
TEX 190PE, TEX 190PE US hexagon 25 x 108 mm (1 x 4¼ in.)	6
TEX 190PE hexagon 28 x 160 mm (1⅛ x 6¼ IN.)	10
Working tools	13
ISO standard hexagon 25 x 108 mm (1 x 4¼ in.)	13
ISO standard hexagon 28 x 160 mm (1⅛ x 6¼ in.)	14
US standard hexagon 1 x 4¼ in. (25 x 108 mm)	15
US standard hexagon 1⅛ x 6 in. (28 x 152 mm)	16
Accessories	17
Pre-mounted rubber hoses with claw couplings	17
Water separator	17
Lubricator	17
Breaker and hammer AIR-OIL	17
Claw couplings	18
Shank gauge	18

General information

This spare parts list applies to the following:

Description

Handheld pneumatic breaker TEX 190PE 25 x 108 mm (1 x 4¼ in.)

Handheld pneumatic breaker TEX 190PE US 25 x 108 mm (1 x 4¼ in.)

Handheld pneumatic breaker TEX 190PE 28 x 160 mm (1½ x 6¼ in.)

Use only authorized parts. Any damage or malfunction caused by the use of unauthorized parts is not covered by Warranty or Product Liability. Any unauthorized use or copying of the contents or any part thereof is prohibited. This applies in particular to trademarks, model denominations, part numbers, and drawings.

Instructions for use

This spare parts list contains no safety regulations and is merely intended to assist in the ordering of spare parts.

For information about operating, servicing, or repairing, the relevant Safety and operating instructions must be consulted at all costs.

Please observe the safety instructions listed in the relevant Safety and operating instructions!

Spare parts list

TEX 190PE, TEX 190PE US hexagon 25 x 108 mm (1 x 4¼ in.)

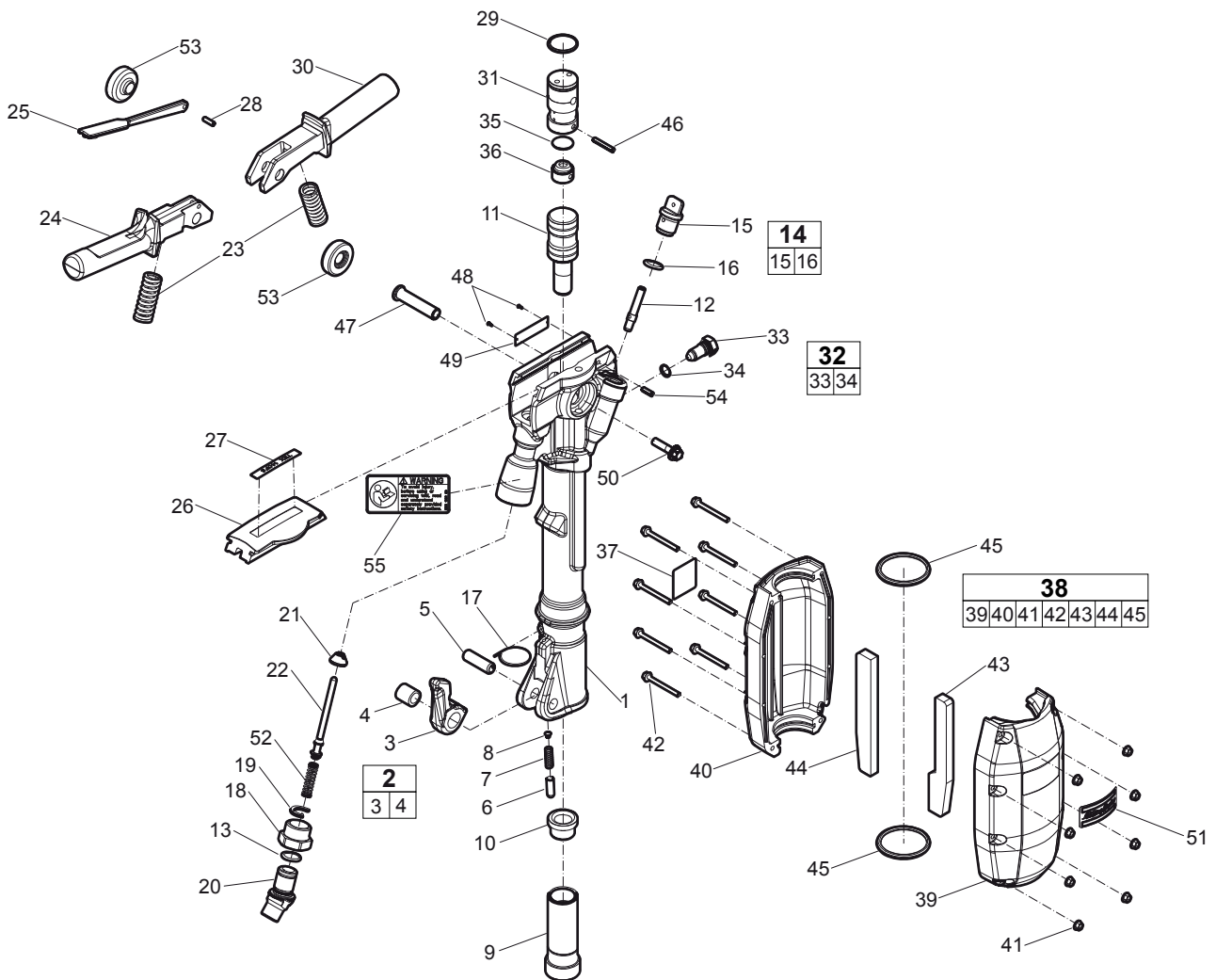

No.	Description	Remark	Quantity	Part number
1	Cylinder		1	3310 1531 00
2(3-4)	Tool retainer, complete		1	3310 0890 80
3	Tool retainer		1	-
4	Bushing		1	3310 0891 00
5	Spring pin		1	0108 1691 05
6	Plunger		1	3310 0893 00
7	Spring		1	3310 0894 00
8	Protection plug		1	3310 1508 00
9	Chuck	Hexagon 25 x 108 mm Hexagon 1 x 4¼ in.	1	3310 1490 00
10	Intermediate part		1	3310 1491 00
11	Piston		1	3310 1489 00
12	Dosing feeder		1	3310 1260 00
13	O-ring	Ø22.2 x 3 mm (70 Shore) Ø0.87 x 0.12 in.	1	0663 2126 00
14(15-16)	Oil plug, complete		1	3310 1462 80
15	Oil plug		1	-
16	O-ring	Ø22.2 x 3 mm (70 Shore) Ø0.87 x 0.12 in.	1	0663 2126 00
17	Lock wire		1	3310 1534 00
18	Swivel nut		1	3310 1044 00
19	Lock washer		1	3310 1059 00
20	Swivel		1	3310 1536 00
21	Inlet valve		1	3310 1211 00
22	Valve stem		1	3310 1492 00
23	Spring		2	3310 1083 00
24	Handel		1	3310 1458 80
25	Trigger		1	3310 1460 80
26	Cover		1	3310 1478 00
27	Label	"TEX 190PE"	1	3310 1516 05
28	Spring pin	Ø6 x 20 mm DIN 1481	1	0108 1324 00
29	O-ring	Ø36.2 x 3 mm (70 Shore) Ø1.43 x 0.12 in.	1	0663 2132 00
30	Handle		1	3310 1459 80
31	Valve housing		1	3310 1488 00
32(33-34)	Screw, complete		1	3310 1476 80
33	Screw		1	-
34	O-ring	Ø13.3 x 2.4 mm (70 Shore) Ø0.52 x 0.09 in.	1	0663 2120 00
35	Main valve		1	3310 1173 00
36	Valve cover		1	3310 1245 00
37	Sound power label		1	-
38(39-45)	Silencer, complete		1	3310 1512 81
39	Front		1	-
40	Rear		1	-
41	Flange nut		8	9232 0207 50
42	Flange screw		8	0147 3000 32
43	Separation wall		1	3310 1518 10
44	Separation wall		1	3310 1518 11
45	O-ring	Ø64.2 x 5.7 mm Ø2.53 x 0.22 in.	2	0663 2114 13
46	Spring pin	Ø6 x 40 mm DIN 1481	1	0108 1332 00
47	Guide shaft		1	3310 1479 01
48	Screw		2	0244 4144 00
49	Data plate		1	-

No.	Description	Remark	Quantity	Part number
50	Flange screw	M10 x 40 mm	1	0147 3000 18
51	Label	"Atlas Copco"	1	0690 1356 00
52	Spring		1	3310 1537 00
53	Buffer		2	3310 1461 15
54	Spring pin	Ø6 x 16 mm DIN 1481	1	0108 1322 00
55	Safety label		1	3310 1602 00

No.	Description	Remark	Quantity	Part number
1	Cylinder		1	3310 1532 00
2(3-4)	Tool retainer, complete		1	3310 0890 80
3	Tool retainer		1	-
4	Bushing		1	3310 0891 00
5	Spring pin		1	0108 1691 05
6	Plunger		1	3310 0893 00
7	Spring		1	3310 0894 00
8	Protection plug		1	3310 1508 00
9	Tool chuck	Hexagon 28 x 160 mm Hexagon 1 $\frac{1}{8}$ x 6 $\frac{1}{4}$ in.	1	3310 1498 00
10	Intermediate part		1	3310 1491 00
11	Piston		1	3310 1489 00
12	Dosing feeder		1	3310 1260 00
13	O-ring	Ø22.2 x 3 mm (70 Shore) Ø0.87 x 0.12 in.	1	0663 2126 00
14(15-16)	Oil plug, complete		1	3310 1462 80
15	Oil plug		1	-
16	O-ring	Ø22.2 x 3 mm (70 Shore) Ø0.87 x 0.12 in.	1	0663 2126 00
17	Lock wire		1	3310 1534 00
18	Swivel nut		1	3310 1044 00
19	Lock washer		1	3310 1059 00
20	Swivel		1	3310 1536 00
21	Inlet valve		1	3310 1211 00
22	Valve stem		1	3310 1492 00
23	Spring		2	3310 1083 00
24	Handle		1	3310 1458 80
25	Trigger		1	3310 1460 80
26	Cover		1	3310 1478 00
27	Label	"TEX 190PE"	1	3310 1516 05
28	Spring pin	Ø6 x 20 mm DIN 1481	1	0108 1324 00
29	O-ring	Ø36.2 x 3 mm (70 Shore) Ø1.43 x 0.12 in.	1	0663 2132 00
30	Handle		1	3310 1459 80
31	Valve housing		1	3310 1488 00
32(33-34)	Screw, complete		1	3310 1476 80
33	Screw		1	-
34	O-ring	Ø13.3 x 2.4 mm (70 Shore) Ø0.52 x 0.09 in.	1	0663 2120 00
35	Main valve		1	3310 1173 00
36	Valve cover		1	3310 1245 00
37	Sound power label		1	-
38(39-45)	Silencer, complete		1	3310 1477 83
39	Front		1	-
40	Rear		1	-
41	Flange nut		10	9232 0207 50
42	Flange screw		10	0147 3000 32
43	Separation wall		1	3310 1518 20
44	Separation wall		1	3310 1518 21
45	O-ring	Ø64.2 x 5.7 mm Ø2.53 x 0.22 in.	2	0663 2114 14
46	Spring pin	Ø6 x 40 mm DIN 1481	1	0108 1332 00
47	Guide shaft		1	3310 1479 01
48	Screw		2	0244 4144 00
49	Data plate		1	-

No.	Description	Remark	Quantity	Part number
50	Flange screw	M10 x 40 mm	1	0147 3000 18
51	Label	"Atlas Copco"	1	0690 1356 00
52	Spring		1	3310 1537 00
53	Buffer		2	3310 1461 15
54	Spring pin	Ø6 x 16 mm DIN 1481	1	0108 1322 00
55	Safety label		1	3310 1602 00

Working tools

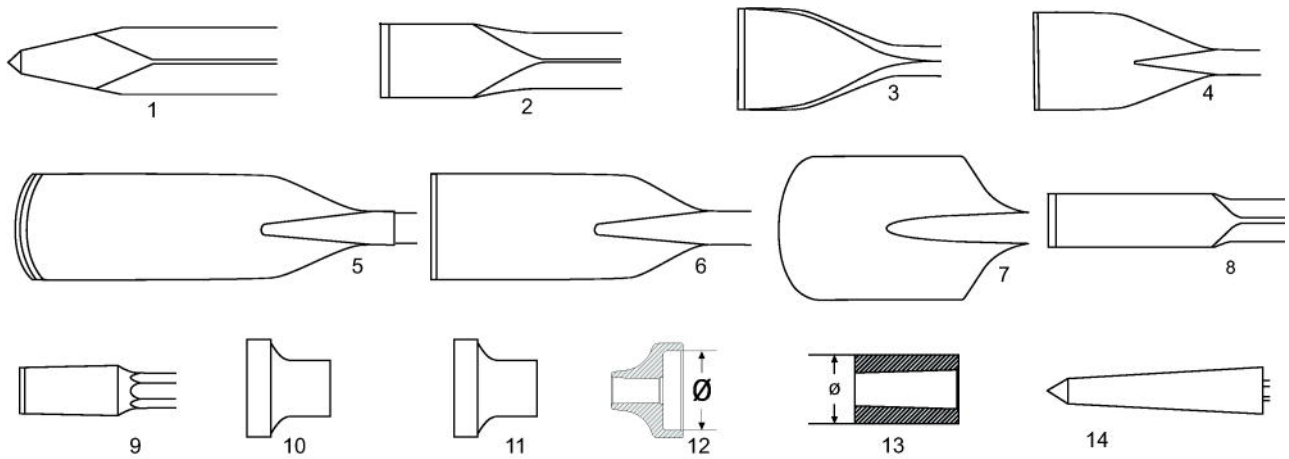

ISO standard hexagon 25 x 108 mm (1 x 4¼ in.)

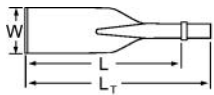

Point to flat

No.	Description	W (mm)	L (mm)	L _T (mm)	Wt (kg)	Part number
1	Moil point	-	380	500	2.0	3083 3253 00
2	Narrow chisel	-	380	500	2.1	3083 3254 00
3	Wide chisel	75	380	500	2.3	3083 3255 00
5	Digging chisel	75	380	500	3.1	3083 3256 00
6	Digging spade	120	380	500	4.2	3083 3257 00
7	Clay spade	125	430	550	3.8	3083 3033 00
8	Wedge chisel	35	380	500	2.5	3083 3258 00
9	Shaft for tamping pad	-	280	400	2.1	3083 3259 00
10	Tamping pad, round	ø175	-	-	7.6	3083 3252 10
11	Tamping pad, square	175	-	-	6.1	3083 3239 00
12	Driver pad, round	ø100	-	-	2.6	9245 2817 90
		ø65	-	-	1.9	3371 8060 12
14	Posthole pad	40	-	-	2.7	9245 2822 30

ISO standard hexagon 28 x 160 mm (1¹/₈ x 6¹/₄ in.)

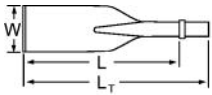

Point to flat

No.	Description	W (mm)	L (mm)	L _T (mm)	Wt (kg)	Part number
1	Moil point	-	380	545	2.9	3083 3271 00
		-	450	615	3.2	3083 3272 00
		-	1000	1165	6.2	3083 3273 00
2	Narrow chisel	-	380	545	2.8	3083 3274 00
		-	450	615	3.3	3083 3275 00
		-	1000	1165	6.4	3083 3276 00
3	Wide chisel	75	380	545	3.0	3083 3277 00
4	Asphalt cutter	115	300	465	3.7	3083 3278 00
5	Digging chisel	75	380	545	4.1	3083 3279 00
6	Digging spade	125	380	545	4.6	3083 3280 00
7	Clay spade	140	380	545	4.1	3083 3281 00
8	Wedge chisel	40	400	565	3.9	3083 3282 00
9	Shaft for tamping pad	-	230	395	3.0	3083 3283 01
10	Tamping pad, round	Ø180	-	-	7.1	3083 3301 00
11	Tamping pad, square	150	-	-	8.2	3083 3302 00
		200	-	-	10.0	3083 3197 00
12	Driving pad	Ø120	-	-	7.6	3376 1120 79
		Ø150	-	-	8.7	3376 1120 77
13	Driver blank	Ø80	-	-	3.4	9245 2827 10

US standard hexagon 1 x 4¼ in. (25 x 108 mm)

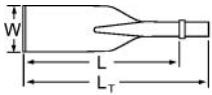

Flat to flat

No.	Description	W (in.)	L (in.)	L _T (in.)	Wt (lb)	Part number
1	Moil point	-	15	20	4.6	3083 4030 00
		-	18	22	5.3	3083 4030 10
		-	24	29	6.8	3083 4030 20
		-	36	41	9.7	3083 4030 30
2	Narrow chisel	-	15	20	4.6	3083 3309 00
		-	18	22	5.3	3083 4031 10
		-	24	29	6.8	3083 4031 20
		-	36	41	9.7	3083 4031 30
3	Wide chisel	3	15	20	5.3	3083 3310 00
		3	18	22	5.7	3083 4032 00
		3	24	29	7.3	3083 4032 10
		3	36	41	10.3	3083 4032 20
4	Asphalt cutter	4½	12	16¾	7.1	3083 4034 00
		5	13	17¾	6.4	3083 4033 00
5	Digging chisel	3	15	20	7.0	3083 3311 00
6	Digging spade	4¾	13	17¾	8.8	3083 3312 00
7	Clay spade	4	16	21	6.2	3083 4035 10
		5	16	21	8.2	3083 4035 00
8	Wedge chisel	2	15	20	10.4	3083 3313 00
9	Shaft for tamping pad	-	11	16	4.2	3083 4037 00
10	Tamping pad, round	ø7	-	-	16.8	3083 3252 10
11	Tamping pad, square	7	-	-	13.5	3083 3239 00
12	Driver pad, round	ø4	-	-	5.7	9245 2817 90
		ø2½	-	-	4.2	3371 8060 12
14	Posthole pad	1½	-	-	6.0	9245 2822 30

US standard hexagon 1 $\frac{1}{8}$ x 6 in. (28 x 152 mm)

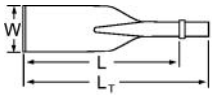

Flat to flat

No.	Description	W (in.)	L (in.)	L _T (in.)	Wt (lb)	Part number
1	Moil point	-	14	20	6.0	3083 3267 00
		-	18	24	7.1	3083 4015 10
		-	24	30	9.0	3083 4015 20
		-	36	42 $\frac{1}{2}$	12.8	3083 4015 30
2	Narrow chisel	-	14	20	6.0	3083 3268 00
		-	18	24	7.1	3083 4016 10
		-	24	30 $\frac{1}{2}$	9.0	3083 4016 20
		-	36	42 $\frac{1}{2}$	12.8	3083 4016 30
3	Wide chisel	3	15	21	6.8	3083 3289 00
		3	18	24	7.7	3083 4017 00
		3	24	31	9.5	3083 4017 10
		3	36	42 $\frac{1}{2}$	13.0	3083 4017 20
4	Asphalt cutter	4 $\frac{1}{2}$	11	17 $\frac{1}{2}$	7.7	3083 4019 00
		5	13	19 $\frac{1}{2}$	9.0	3083 3290 00
5	Digging chisel	3	15	21	9.0	3083 3291 00
6	Digging spade	5	13	19	9.0	3083 3292 00
7	Clay spade	5 $\frac{1}{2}$	15	21	9.9	3083 3293 00
8	Wedge chisel	2	16	22	11.0	3083 3294 00
9	Shaft for tamping pad	-	9	16	6.4	3083 3269 00
10	Tamping pad, round	Ø7	-	-	15.7	3083 3301 00
11	Tamping pad, square	6	-	-	18.1	3083 3302 00
		8	-	-	22.0	3083 3197 00
12	Driving pad	Ø4 $\frac{3}{4}$	-	-	16.8	3376 1120 79
		Ø6	-	-	19.2	3376 1120 77
13	Driver blank	Ø3	-	-	7.5	9245 2827 10

Accessories

Pre-mounted rubber hoses with claw couplings

Description	Remark	Quantity	Part number
Rubber hose, pre-mounted with European type claw couplings, 3 m (10 feet) (claw couplings on both ends)	Ø20 mm Ø¾ in.	1	9030 2100 00
Rubber hose, pre-mounted with European type claw couplings, 3 m (10 feet) (1 x claw coupling + 1 x hose nipple with cup nut)	Ø20 mm Ø¾ in.	1	9030 2048 00

Water separator

Description	Remark	Quantity	Part number
Water separator VAM 01, European type claw couplings	Airflow < 50 l/s Airflow < 106 ft³/min	1	8092 0110 58
Water separator VAM 01, US type claw couplings	Airflow < 50 l/s Airflow < 106 ft³/min	1	8092 0110 59
Water separator VAM 5A, European type claw couplings	Airflow < 120 l/s Airflow < 254 ft³/min	1	8092 0110 82
Water separator VAM 5A, US type claw couplings	Airflow < 120 l/s Airflow < 254 ft³/min	1	8092 0110 83

Lubricator

Description	Remark	Quantity	Part number
Lubricator CLG 30, European type claw couplings	For mineral and synthetic oil	1	8202 5102 39
Lubricator CLG 30, US type claw couplings	For mineral and synthetic oil	1	8202 5102 40

Breaker and hammer AIR-OIL

Description	Remark	Quantity	Part number
Breaker and hammer AIR-OIL	0.25 l 0.06 US gallon	1	8099 0202 40
Breaker and hammer AIR-OIL	1 l 0.26 US gallon	1	8099 0202 36
Breaker and hammer AIR-OIL (pack)	1 l 0.26 US gallon	20	8099 0202 81
Breaker and hammer AIR-OIL	5 l 1.32 US gallon	1	8099 0202 02
Breaker and hammer AIR-OIL (pack)	5 l 1.32 US gallon	4	8099 0202 85

Claw couplings

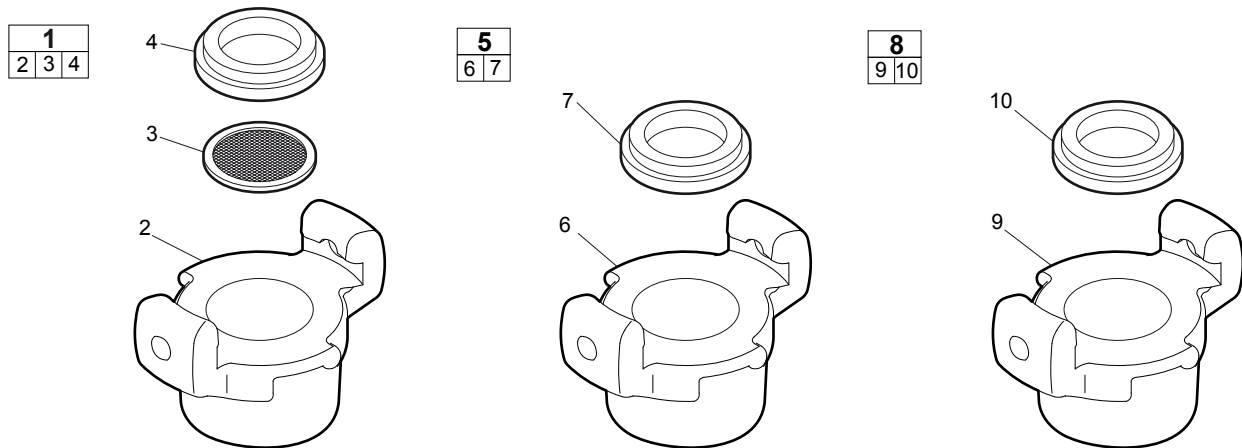

No.	Description	Remark	Quantity	Part number
1(2-4)	Claw coupling with strainer, complete		1	9000 0306 01
2	Claw coupling	Standard G $\frac{3}{4}$ in.	1	-
3	Strainer		1	9000 0000 10
4	Seal		1	9000 0000 00
5(6-7)	Claw coupling, complete		1	9000 0306 00
6	Claw coupling	Standard G $\frac{3}{4}$ in.	1	-
7	Seal		1	9000 0000 00
8(9-10)	Claw coupling, complete		1	9001 0005 06
9	Claw coupling	US-universal $\frac{3}{4}$ in.	1	-
10	Seal		1	9001 0005 15

Shank gauge

Description	Remark	Quantity	Part number
Gauge, hexagon	25 mm 1 in.	1	3310 1509 25
Gauge, hexagon	28 mm 1 $\frac{1}{8}$ in.	1	3310 1509 28



Any unauthorized use or copying of the contents or any part thereof is prohibited.
This applies in particular to trademarks, model denominations, part numbers, and drawings.

© 2010 Atlas Copco Construction Tools AB | No. 9800 0857 01c | 2010-11-26

www.atlascopco.com